

AdaptaBeacon® Light Duty Strobe

Weatherproof

92-R5 and -S1 Series

FEATURES

- > Optically designed fresnel lens
- > Xenon flash tube
- > Immune to shock and vibration
- > Cast base can be utilized as a junction box

AGENCY APPROVALS

- > UL 1638 Listed (92-R5)
- > cUL Listed

The Edwards 92 Series AdaptaBeacon Light Duty strobe features convenient size and brilliant light output. Complementing fresnels cause the dome to "fill" with light each time the strobe flashes. This design feature increases the AdaptaBeacon "on-time", thus improving viewer perception. Beam distance is increased with external fresnel lenses. Lenses are available in six colors: red, amber, blue, green, magenta and clear.

The 92 Series' trigger and timing circuits are included as integral parts of the power supply. Replacement costs are reduced as it is necessary to replace only the strobe tube.

Designed for indoor or outdoor installation. May be direct, 1/2" (13mm) conduit, or box mounted on a 4" (102mm) octagon box on any plane. However, vertical installation ensures maximum beam width projection. For weatherproof installations units must be mounted vertically with dome up. May be corner mounted using the Cat. No. CBR, corner mount bracket, or wall mounted using the Cat. No. WBR, wall mount bracket. Cat. No. 92-GRD lens guard is available for additional protection against lens breakage. See AdaptaBeacon Accessories on page 3-118.

92 Series strobes have been designed for light duty applications in industrial, commercial, and institutional applications where short term intermittent visual signaling is required. They are ideally suited for installations where high ambient light levels make traditional rotating or flashing lights difficult to distinguish or where ambient noise levels make audible signals difficult to hear.



TECHNICAL INFORMATION

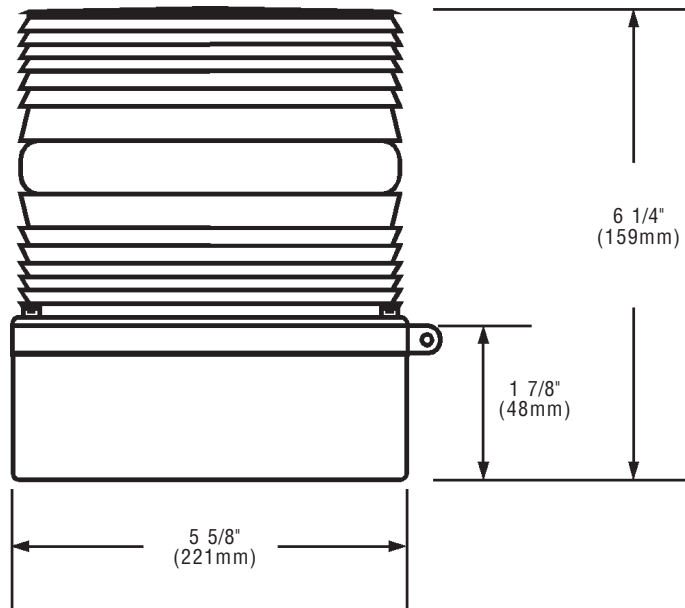

| Cat. No. | Lens Color | Replacement Lens | Electrical Rating | Peak Candlepower | Flash Rate | Replacement Strobe Tube |
|----------|------------|------------------|-------------------|------------------|------------|-------------------------|
| 92R-S1 | Red | V93-LR | 250V DC | 800,000 | 65 FPM | 92-ST |
| 92A-S1 | Amber | V93-LA | 0.05 Amps | | | 3,000 hour* |
| 92B-S1 | Blue | V93-LB | | | | |
| 92G-S1 | Green | V93-LG | | | | |
| 92M-S1 | Magenta | V93-LM | | | | |
| 92C-S1 | Clear | V93-LC | | | | |
| 92R-R5 | Red | V93-LR | 240V 50/60 Hz | 800,000 | 65 FPM | 92-ST |
| 92A-R5 | Amber | V93-LA | 0.05 Amps | | | 3,000 hour* |
| 92B-R5 | Blue | V93-LB | | | | |
| 92G-R5 | Green | V93-LG | | | | |
| 92M-R5 | Magenta | V93-LM | | | | |
| 92C-R5 | Clear | V93-LC | | | | |

*Calculated at operating power to 75% efficiency.